

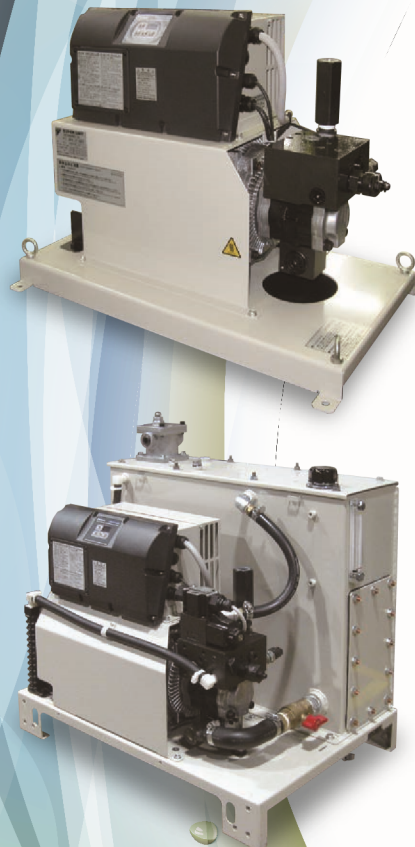

# SUPER UNIT

## INVERTER HYDRAULIC UNIT

Excluded from high-efficiency motor regulations



## INDEX

List of Hybrid Hydraulic Unit Models	P.3 to 4
List of Super Unit Models Nomenclature	P.5
Main Features and Functions Super Unit Hydraulic Circuits	P.6
Features	P.7 to 8
Functions	P.9
Function Option	P.10
Hardware Option	P.11 to 12
Pressure – Flow Rate Characteristics (Typical)	P.13 to 14
Specifications/External Dimension Diagram ▶ 7 MPa	P.15 to 24
Specifications/External Dimension Diagram ▶ 10 MPa	P.25 to 28
Specifications/External Dimension Diagram ▶ 16 MPa	P.29 to 32
Specifications/External Dimension Diagram ▶ 21 MPa	P.33 to 38
Operation Panel	P.39 to 40
Electric Wiring	P.41 to 43
Options (Separately available parts)	P.44. to 48
Method of Selection	P.49
Handling	P.50

# Get more than energy savings!!

Saving energy is essential.

However, the Daikin hydraulic system goes one step further than conventional models.

Daikin practices environmentally friendly production by promoting energy savings in the production field and by reducing waste through recycling.

In the pursuit of higher usability and more diversified functions, Daikin combined its original high-efficiency IPM motors and pump switching control technology. The Super Unit incorporates the multi-stage pressure/flow rate control system as well as the functions of conventional hydraulic units, resulting in the use of fewer valves.

Daikin intends to promote energy savings through advanced hydraulic systems with the aim of contributing to improvement of factory environments, and to continuously introduce hydraulic systems that lead the industry.



# Combining Daikin's original high-efficiency IPM motors and hydraulic technology enables an unparalleled energy-saving effect and advanced functions.

## Energy-saving technology that supports hybrid products

- ◆ Daikin was the first in the industry to introduce an interior permanent magnet synchronous motor (IPM motor) into air conditioners for household use. Daikin was also an early adopter in the industry of the IPM motor for use in industrial-use air conditioners. We have led the industry as a front runner in air conditioner energy-saving performance.
- ◆ Hybrid products equipped with variable speed motors, developed by making full use of Daikin's original energy-saving motor technology and its production capacity, help to achieve energy savings for factory equipment



Powerful neodymium magnets, the key to this improved energy-saving effect!

### "Double torque" improves the energy-saving effect.

Combining two rotational forces, "magnetic torque" generated by a powerful neodymium magnet\*1 and "reluctance torque"\*2, generates more power with less electricity.

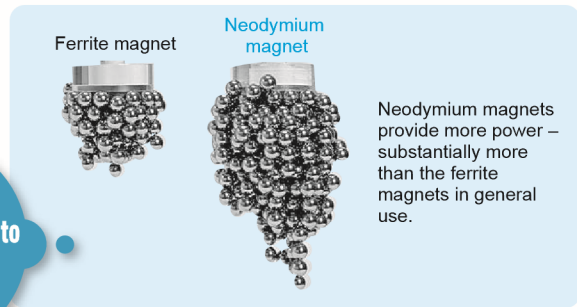

※1: A compound of neodymium (Nd, rare-earth element), iron (Fe), and boron (B). Neodymium magnets are known to have superior magnetic properties.  
 ※2: Rotational force generated by attractive force (reluctance = magnetic resistance) between iron and a magnet.

## Fundamental Principle of the IPM Motor

With a rare-earth permanent magnet deeply embedded in the rotor, the IPM motor uses an electromagnetic structure that maximizes magnetic torque (attractive/repulsive force between the coil and permanent magnet) and reluctance torque (force of the coil that attracts iron).

This structure achieves high torque and maximum efficiency while suppressing heat generation.

### Structure of the IPM motor

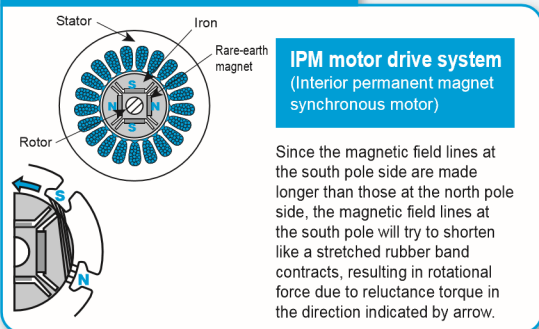

### Structure of a conventional motor (AC servomotor)

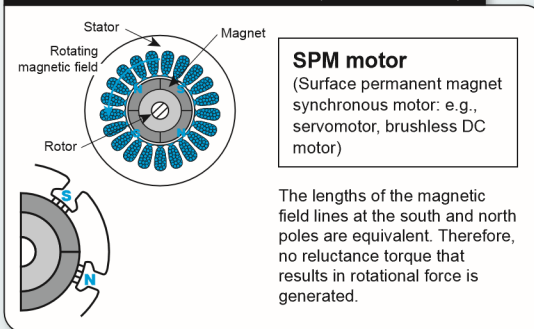

### [1] Comparison of motor efficiency

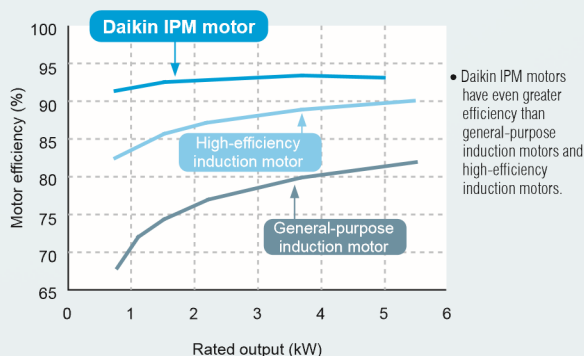

### [2] Large torque at low speed

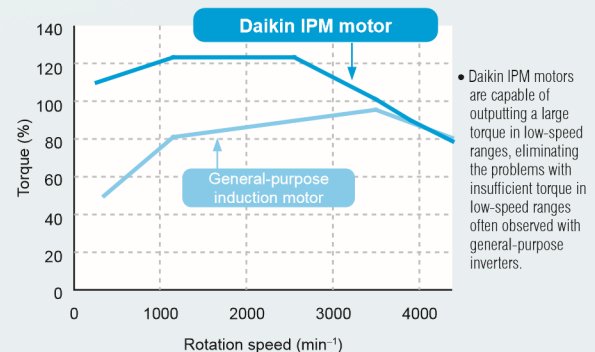

# Hybrid Hydraulic Unit Model List

Specifications vary depending on the machine  
The Daikin product lineup provides various

## For machine tools

Maximum discharge rate

110 L/min

80 L/min

60 L/min

40 L/min

30 L/min

28.5 L/min

25 L/min

15 L/min

Maximum operating pressure

4 MPa

6 MPa

7 MPa

7 MPa

7 MPa

7 MPa

**EHU25-L04**  
Equivalent to **1.5 kW**



**EHU30-M07**  
Equivalent to **2.8 kW**



**EHU25-L07**  
Equivalent to **2.2 kW**  
**EHU25-M07**  
Equivalent to **2.8 kW**



**EHU30R-M07**  
Equivalent to **2.8 kW**



**EHU15R-M07**  
Equivalent to **2.2 kW**



**EHU30S-M075R**  
Equivalent to **1.5 kW**



**SUT00S11007**

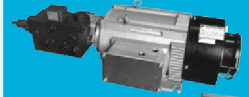

Equivalent to **11.0 kW**

See Pages 23 to 24

**16**  
PQ

**C**  
Communication

**A**  
Analog

**SUT00S8007**



Equivalent to **7.0 kW**

See Pages 21 to 22

**16**  
PQ

**C**  
Communication

**A**  
Analog

**SUT10S8007**



**SUT00S6007**

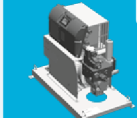

Equivalent to **5.0 kW**

See Pages 19 to 20

**16**  
PQ

**C**  
Communication

**A**  
Analog

**SUT06S6007**



**SUT00S4007**

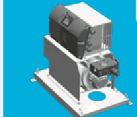

Equivalent to **3.7 kW**

See Pages 17 to 18

**16**  
PQ

**C**  
Communication

**A**  
Analog

**SUT03S4007**

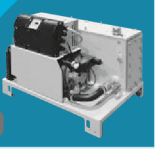

**SUT00S3007**

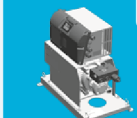

Equivalent to **2.8 kW**

See Pages 15 to 16

**16**  
PQ

**C**  
Communication

**A**  
Analog

**SUT03S3007**

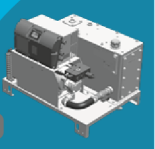

**SUT00S1507**

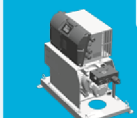

Equivalent to **2.2 kW**

See Pages 15 to 16

**16**  
PQ

**C**  
Communication

**A**  
Analog

**SUT03S1507**

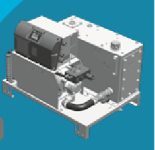

**16**  
PQ

16-pattern PQ control

**Idle**

Idling stop

**C**

Communication function

**A**

Analog command input

# type. functions and capacities according to the machine type.

## For general industrial machines

### Super Unit (high-performance type)

SUT00D11021



**16**  
PQ **C**  
Communicator

P-SUT20D11KW

Equivalent to  
**11.0 kW**

See Pages 37 to 38

SUT00D8021



**16**  
PQ **C**  
Communicator

SUT10D8021  
SUT16D8021

Equivalent to  
**7.0 kW**

See Pages 35 to 36

SUT00D6021

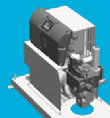

**16**  
PQ **C**  
Communicator

SUT06D6021  
SUT10D6021

Equivalent to  
**5.0 kW**

See Pages 33 to 34

SUT00D4016

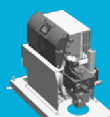

**16**  
PQ **C**  
Communicator

SUT06D4016

Equivalent to  
**3.7 kW**

See Pages 31 to 32

SUT00S3010



**16**  
PQ **C** **A**  
Communication Analog

SUT03S3010

Equivalent to  
**3.7 kW**

See Pages 27 to 28

SUT00S3016



**16**  
PQ **C** **A**  
Communication Analog

SUT06S3016

Equivalent to  
**5.0 kW**

See Pages 29 to 30

SUT00S1510



**16**  
PQ **C** **A**  
Communication Analog

SUT03S1510

Equivalent to  
**2.8 kW**

See Pages 25 to 26

SUT00S1516



**16**  
PQ **C** **A**  
Communication Analog

SUT03S1516

Equivalent to  
**3.7 kW**

See Pages 29 to 30

**10 MPa**

**16 MPa**

**21 MPa**

Maximum  
operating pressure

**18 MPa**

**21 MPa**

Maximum  
discharge rate

**200 L/min**

**150 L/min**

**130 L/min**

**80 L/min**

**50 L/min**

**30 L/min**

### Super Unit (high-precision type)

SUT00S20018



**A**  
Analog

Equivalent to  
**22.0 kW**

SUT00S15018



**A**  
Analog

Equivalent to  
**15.0 kW**

SUT00S13021



**A**  
Analog

Equivalent to  
**15.0 kW**

SUT00S8018



**A**  
Analog

Equivalent to  
**11.0 kW**

SUT00S5021



**A**  
Analog

Equivalent to  
**11.0 kW**

SUT00S3018



**A**  
Analog

Equivalent to  
**7.0 kW**

\*1: The above motor capacities are given for guidance only and do not represent the standard capacities of general motors.

\*2: When selecting a Super Unit, verify the specifications of each model by referring to "Pressure – Flow rate Characteristics (Typical)" on Pages 13 and 14 and "How to Select a Super Unit" on Page 49.  
For the purpose of making improvements, the specifications given in this catalog are subject to change without prior notice. Be sure to see the latest model chart.

# List of Super Unit models

## Selecting the optimum model from a wide variety of Super Unit models

Series	Motor capacity	Maximum operating pressure (MPa)	Maximum flow rate (L/min)											Tankless type	Unit type	Tank capacity (L)	Page			
			10	20	30	40	50	60	70	80	90	100	110							
Super Unit	Single pump type	Equivalent to 2.2 kW	7.0	■												SUT00S1507-30	SUT03S1507-30	30	15 to 16	
		Equivalent to 2.8 kW	7.0	■	■											SUT00S3007-30	SUT03S3007-30	30		
		Equivalent to 3.7 kW	7.0	■	■	■										SUT00S4007-30	SUT03S4007-30	30		
		Equivalent to 5.0 kW	7.0	■	■	■	■									SUT00S6007-30	SUT06S6007-30	60		
		Equivalent to 7.0 kW	7.0	■	■	■	■	■								SUT00S8007-30	SUT10S8007-30	100		
		Equivalent to 11.0 kW	7.0	■	■	■	■	■	■							SUT00S11007-30	—	—		23 to 24
		Equivalent to 2.8 kW	10.0	■	■											SUT00S1510-30	SUT03S1510-30	30		25 to 26
	Double pump type	Equivalent to 3.7 kW	10.0	■	■											SUT00S3010-30	SUT03S3010-30	30	27 to 28	
		Equivalent to 3.7 kW	16.0	■	■											SUT00S1516-30	SUT03S1516-30	30	29 to 30	
		Equivalent to 5.0 kW	16.0	■	■										SUT00S3016-30	SUT06S3016-30	60			
		Equivalent to 3.7 kW	15.7	■	■	■										SUT00D4016-30	SUT06D4016-30	60	31 to 32	
		Equivalent to 5.0 kW	20.6	■	■	■										SUT00D6021-30	SUT06D6021-30	60	33 to 34	
				■	■	■									SUT10D6021-30	100				
			20.6	■	■	■	■								SUT00D8021-30	SUT10D8021-30	100	35 to 36		
Equivalent to 7.0 kW	20.6	■	■	■	■								SUT16D8021-30	160						
		Equivalent to 11.0 kW	20.6	■	■	■	■	■						SUT00D11021-30	P-SUT20D11KW-30	200	37 to 38			

## Nomenclature

### Equivalent to 2.2 to 7.0 kW

SUT	03	S	15	07	-	30	-	※	-	※※	-	※※※※
a	b	c	d	e		f		g		h		i

#### a Model No.

- SUT: SUT series

#### b Tank capacity

- 00: Tankless type
- 03: 30 L
- 06: 60 L
- 10: 100 L
- 16: 160 L

#### c Pump type

- D: Double pump type
- S: Single pump type

#### d Pump discharge rate

- 15: 15 L/min
- 30: 25 L/min
- 40: 40 L/min
- 60: 60 L/min
- 80: 80 L/min

#### e Maximum operating pressure

- 07: 7.0 MPa
- 10: 10.0 MPa
- 16: 15.7, 16.0 MPa
- 21: 20.6 MPa

#### f Design No.

- Incremented at model changes 30, ....

#### g Function Option

- C: With communication function (RS232C)
- P: With analog input function

#### h Hardware Option

01	Unit cover (except for 30 L tank)
02	Controller cover (except for 7 kW)
03	DCL (except for 7 kW)
04	Separate power supplies for power system and control system
05	Water fill test compliant tank
06	Water leak test compliant tank
07	Level switch
08	Temperature switch
09	Thermometer
10	Micro separator
11	Combination of 1 to 10 above

#### i Non-standard No.

- N※※※: Without control system
- A※※※: With control system

### Equivalent to 11 kW

SUT	00	S	110	07	-	30	-	※	-	※※※※
a	b	c	d	e		f		g		h

#### a Model No.

- SUT: SUT series

#### b Tank capacity

- 00: Tankless type

#### c Pump type

- D: Double pump type
- S: Single pump type

#### d Pump discharge rate

- 110: 110 L/min

#### e Maximum operating pressure

- 07: 7.0 MPa
- 21: 20.6 MPa

#### f Design No.

- Incremented at model changes 30, ....

#### g Function Option

- C: With communication function (RS232C)
- P: With analog input function

#### h Non-standard No.

- N※※※: Without control system
- A※※※: With control system

## Main features and functions

### Features

1

#### Energy-saving

Daikin's original energy-saving motor technology utilizing high-efficiency IPM motors provides an energy-saving ratio of 50%.

- The motor rotation speed control controls the flow rate and pressure of the fixed displacement pump.
- The highly-efficient motor adopted in this unit achieves energy savings even in applications for general industrial machinery where actuators have high duty ratios.
- The single pump type is a highly-functional series to make it more useful.
- The double pump type uses the autonomously-switching, fixed-displacement double pump system, which combines large- and small-capacity pumps in the low pressure, high flow rate range, and autonomously switches to the single operation of the high-pressure, small capacity pump in the high pressure, low flow rate range. In this way, the double pump type ensures a higher energy-saving effect.

2

#### Low noise

Low noise level of 60 dB (A)

(In the pressure retained operation at 20.6 MPa, with the double pump type unit)

Even over the full operation range, noise is less than 73 dB (A).

- By using double phase-differential pumps, the Super Unit reduces pulsation and the noise level.

\* Data for SUT\*\*D60L21

3

#### Excluded from high-efficiency motor regulations

The Super Units that incorporate a high-efficiency IPM motor are excluded from high-efficiency motor regulations.

4

#### Restricted oil temperature rise

Motor speed control also leads to restriction of the oil temperature rise.

- The restricted oil temperature rise inhibits deterioration of the hydraulic oil.
- This also lowers the heat load for air conditioning equipment

5

#### Fewer control valves required

A wide variety of control can be achieved by adjusting parameter settings.

- Acceleration/deceleration operations that have been accomplished using proportional control valves may be replaced by simply setting the acceleration/deceleration time.
- Pressure switch may be reduced by using the pressure switch function.

(Note that some kinds of control are not applicable depending on the customer's circuit. Care must be taken especially when controlling multiple axes.)

### Functions

1

#### Multi-stage pressure/flow rate control

16  
PQ

Sixteen pressure (P) - flow rate (Q) setting patterns are available for cylinder control.

- The proportional control valve and proportional pressure control valve, which are utilized in conventional actuator circuits, can be omitted.
- The pressure and flow rate can be set using the control unit's operation panel.
- The pressure and flow rate settings can be selected from among the sixteen patterns using external input signals.
- The Super Unit autonomously switches between the pressure control and flow rate control modes.

2

#### Maintenance/Management Function (Hybrid-Win)

Internal data of the Super Unit can be obtained by using PC connected to the unit.



- The pressure, flow rate, and other internal data of the controller can be monitored and displayed in graph form. This facilitates operation checks during test runs, adjustment of parameters such as time constants, and troubleshooting.
- The time required for setting can be slashed by editing the parameter settings on the PC and writing them to the unit in a batch. The ability to read and save settings facilitates management.

3

#### Communication function

(Available as an option with all models)



Remote control and setting changes are possible through RS232C serial communication.

- Using a commercially-available PLC or touch panel display with RS232C communication capabilities, parameters for the pressure, flow rate, acceleration time, deceleration time and so on can be set and viewed at the machine. This facilitates control of speeds and pressurizing forces and enables a wide variety of machine operations.

4

#### Analog command input

(Available as an option with single pump type models)



Enables continuous control of pressures and speeds as required.

- The pressure and flow rate can be controlled continuously at the desired values by inputting the pressure command voltage (0 to 10 V) and flow rate command voltage (0 to 10 V) from the machine side. This achieves a control system with a simple configuration for machinery that requires variable speed control or continuity of pressurizing forces.

## Super Unit hydraulic circuits (example for the unit type)

### Single pump type

※Example with SUT03S1507-30. Refer to the Instruction Manual for each model for details because the port diameter varies depending on the model.

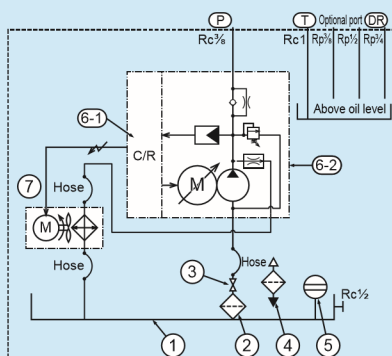

Part No.	Name
1	Tank
2	Suction strainer
3	Stop valve
4	Oil filler port-cum-air breather
5	Oil level gauge
6-1	Controller
6-2	Motor pump incorporating an IPM motor
7	Oil cooler

### Double pump type

※Example with SUT06D4016-30. Refer to the Instruction Manual for each model for details because the circuit configuration varies depending on the model.

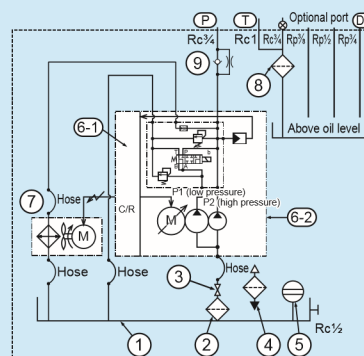

Part No.	Name
1	Tank
2	Suction strainer
3	Stop valve
4	Oil filler port-cum-air breather
5	Oil level gauge
6-1	Controller
6-2	Motor pump incorporating an IPM motor
7	Oil cooler
8	Return filter
9	Check valve with holes

# Features

With excellent energy-saving technology, the Super Unit can substantially reduce electricity costs. The control system can be easily upgraded by combining various Super Unit functions.

## Feature 1 Energy-saving

### ■ Excellent cost effectiveness with energy-saving ratio of 50% (In pressure retained operation at 20.6 MPa)

- Through servo control of Daikin's original high-efficiency IPM motor, the Super Unit ensures both a high response speed and stable rotation speed control with fixed-displacement pumps. In pressure holding mode, the Super Unit autonomously reduces the motor rotation speed to the minimum value required to hold the pressure, thus ensuring energy savings of 50% or higher (compared with the conventional Daikin variable piston pump).
- The Super Unit can even provide an energy-saving effect with general industrial machinery in which actuators provide a high duty ratio, as well as in pressure holding mode.

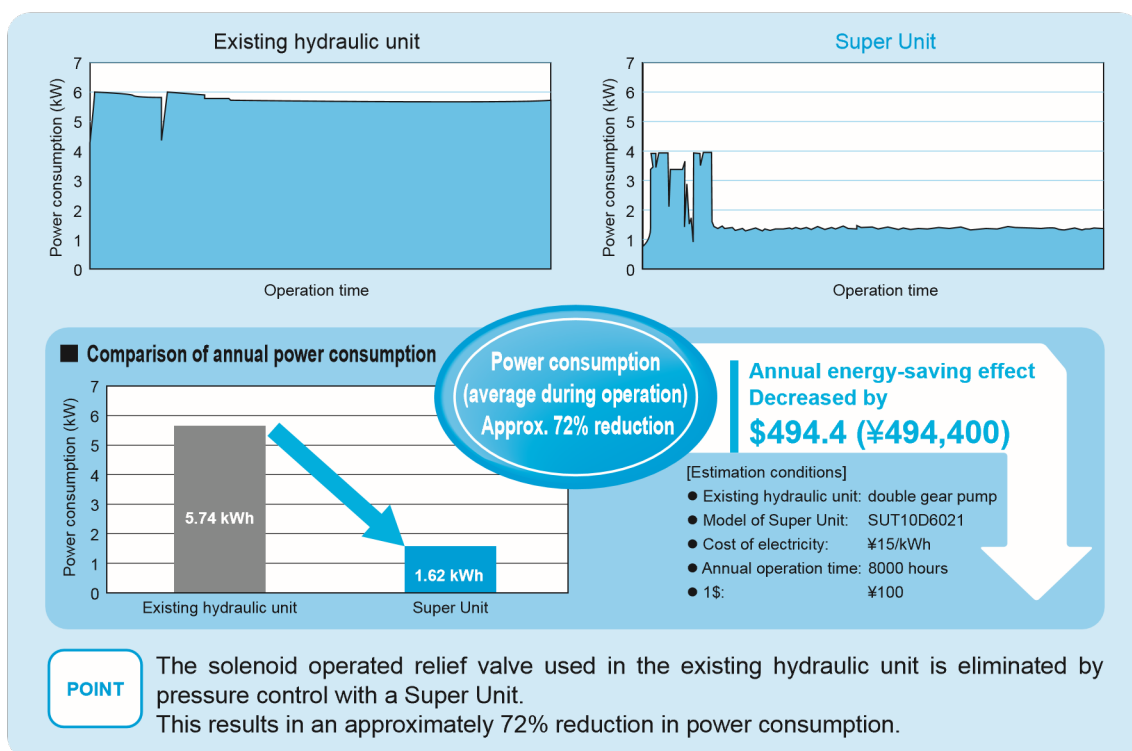

## Feature 2 Low noise

### ■ Low noise level of 60 dB (A) (In pressure retained operation at 20.6 MPa, with the double pump type unit) Even over the full operation range, noise is less than 73 dB (A).

- Running the motor at the minimum required rotation speed in pressure holding mode achieves a remarkable noise level reduction.

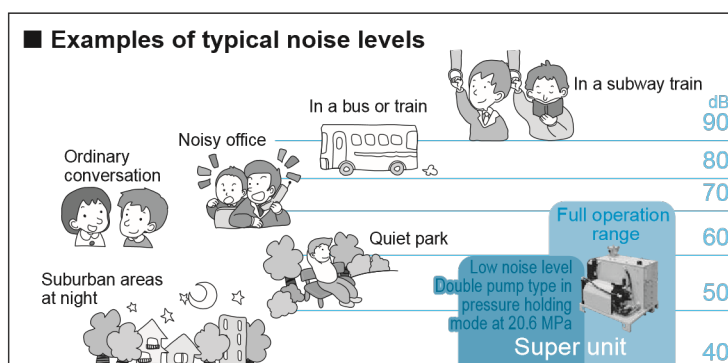

It is generally known that ordinary conversation can be conducted with a person one meter away in an environment at a noise level of 60 dB (A).



Feature **3** Excluded from high-efficiency motor regulations

- High-efficiency motor regulations came into effect in Japan in April 2015. These regulations apply to the hydraulic units equipped with general motors but the Super Units that incorporate a high-efficiency IPM motor are excluded from them.

**Advantages of using hybrid hydraulic units**

- Eliminates the need for replacement of motors for each destination
- Eliminates the need for design changes in accordance with amendments to the regulations
- Reduces design changes to spare parts, and the maintenance workload

Feature **4** All models conforming to CE standards

- All models conform to the machinery directive, EMC directive, and low voltage directive. This facilitates CE approval of the main machine.

Feature **5** Restricted oil temperature rise

- Restriction of the temperature rise of the hydraulic fluid is one of the effects achieved by adopting Super Units. This generates the following advantages.

- Improved machining accuracy**  
Reduced thermal distortion improves the machining accuracy.
- Reduced air-conditioning heat load**  
The reduced heat load on the air conditioner achieves further energy savings.
- Extended service life of packing and other sealing materials**  
Improved maintainability  
Deterioration of the packing and other sealing materials that are made of rubber, used for hydraulic valves and hydraulic cylinders, is restricted.
- Extended service life of the hydraulic fluid**  
Reduced environmental load and improved maintainability  
Restricted deterioration of the hydraulic fluid extends its replacement interval.

Feature **6** Fewer control valves required

Example hydraulic press circuit configuration

